

RECESSED HOOK

TEST METHOD

LOAD CAPACITY
20 kg
44 lbs

NO SCREW

NF-60

BRACKETS & HOOKS

RECESSED HOOKS



PAT.P



- Hook spring loaded to retract.
- Ideal for vibration or shock applications.
- Panel Thickness:
Wood: Min. 20 mm (25/32")
Sheet metal: 0.8 ~ 1.6 mm
*With optional bracket NF-50.

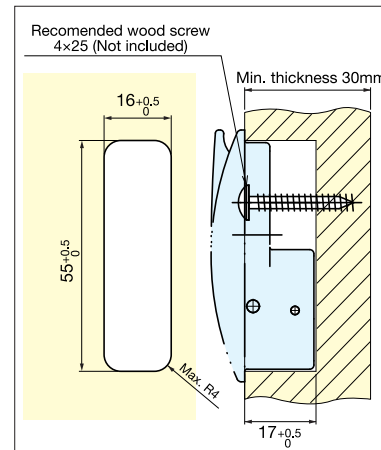
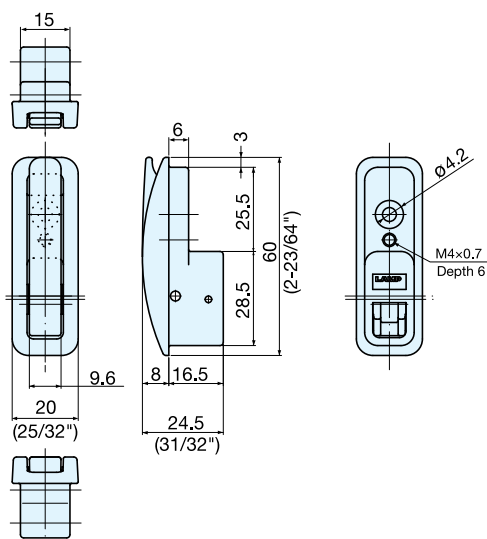

Bore Dimensions
(For thickness over 30mm)

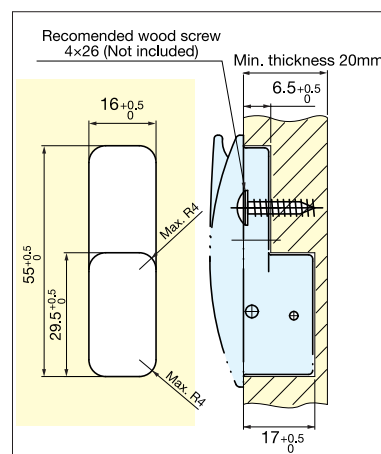

Bore Dimensions
(For thickness 20~29mm)

Item No.	Load Capacity (kg)	Weight (g)	Box (pcs)	Carton (pcs)	Material	Finish
NF-60	20(44 lbs)	31	10	200	Zinc Alloy	Dark Grey Powder Coating

Bracket for sheet metal application



Supplied with M4x20 Stainless steel screw.

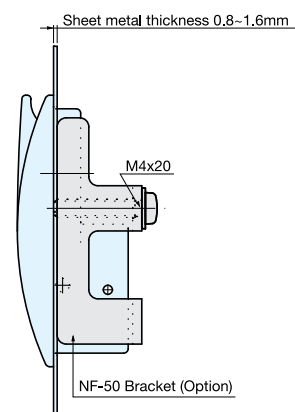
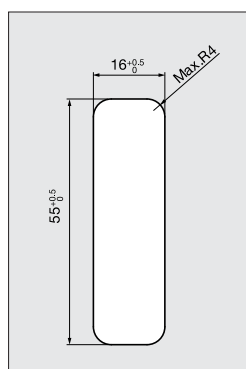
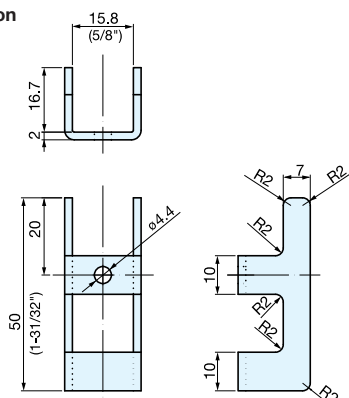

Item No.	Weight (g)	Box (pcs)	Carton (pcs)	Material	Finish
NF-50	22	20	400	Steel	White Zinc Chromate